

Electric high-lift truck ERV 15 ZT 3,3

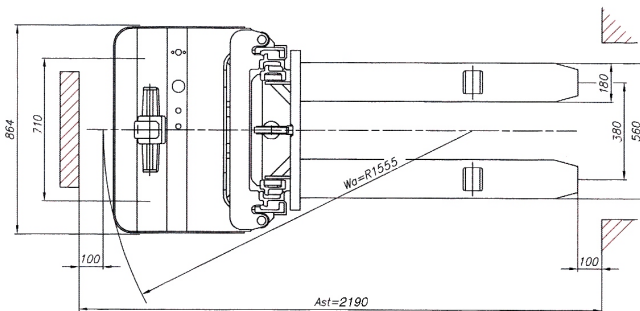
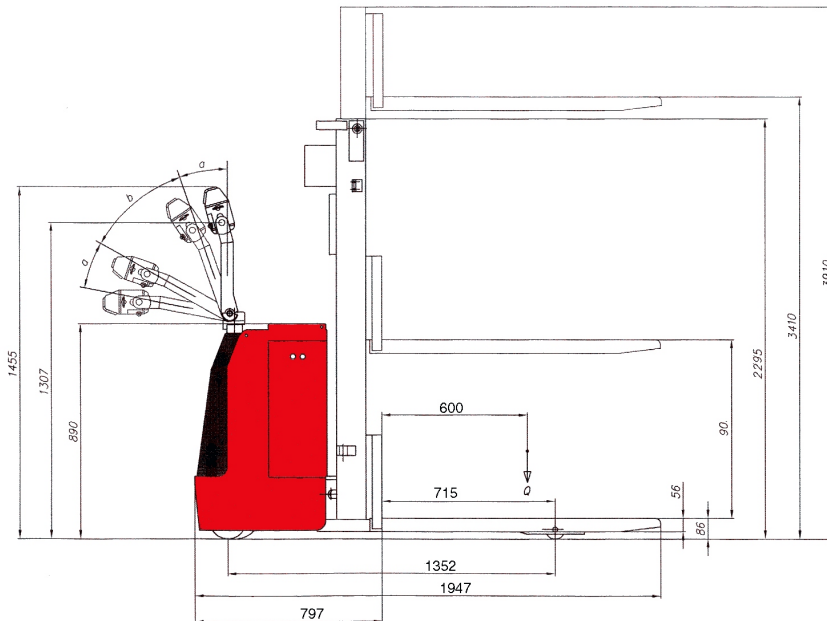

Load capacity	1500	kg.
Lifting height	3300	mm
Height	2295/3910	mm
Diameter of Motor-wheel	Φ 250	mm
Diameter of the supporting wheels	Φ 150 x 40	mm
Diameter of the rollers	Φ 82 x 70	mm
Moving speed with/without load	4,5/5	km/h
Lifting speed with/without load	0,08/0,16	m/s
Lowering speed with/without load	0,16/0,15	m/s
Climbing ability	9/15%	
Parking brake	electric	
Working brake	electric	
Power of the electric motor for moving	S2-60 min	
Power of the electric motor for lifting	1,3	kW
Accumulator battery	3,0	kWh
Charging device	24 V/240Ah	
Type of control	impulse	
Degree of switching	impulse	
Material of the wheels	without degree	
	polyurethane	