

Electric lift truck - combined stacker low/high ERD 20/10

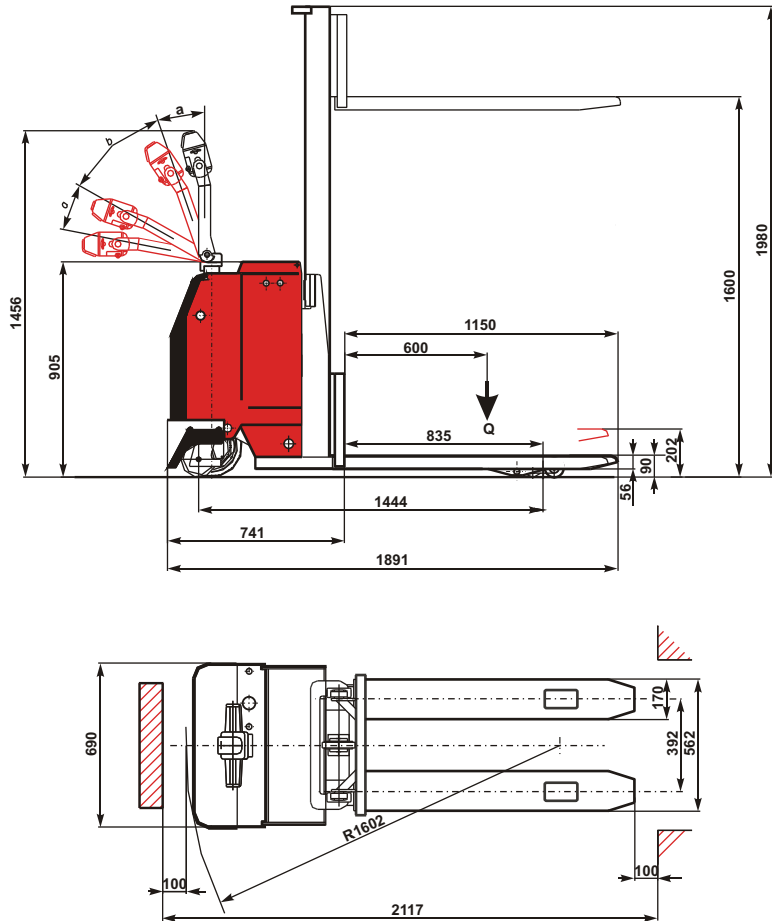

ERD 20/10

Load capacity	2000/1000	kg.
Lifting height	202/1600	mm.
Height	1980	mm.
Diameter of Motor-wheel	Φ 250	mm.
Diameter of the supporting wheels	Φ 150 x 40	mm.
Diameter of the rollers	Φ 82 x 90	mm.
Moving speed with/without load	5	km/h.
Lifting speed without load	0,13/0,16	m/s.
Lifting speed with load	0,051/0,08	m/s.
Lowering speed with/without load	0,16/0,15	m/s.
Climbing ability	9/15	%
Parking brake	electric	
Working brake	electric	
Power of the electric motor for moving	S2-60 min	1,2 kW
Power of the electric motor for lifting	15% ED	2 kW
Accumulator battery	24 V/160	Ah
Charging device	24V/30A	impulse
Type of control		impulse
Degree of switching		without degree
Material of the wheels		polyurethane