

ELECTRIC HIGH-LIFT TRUCK ERT 08

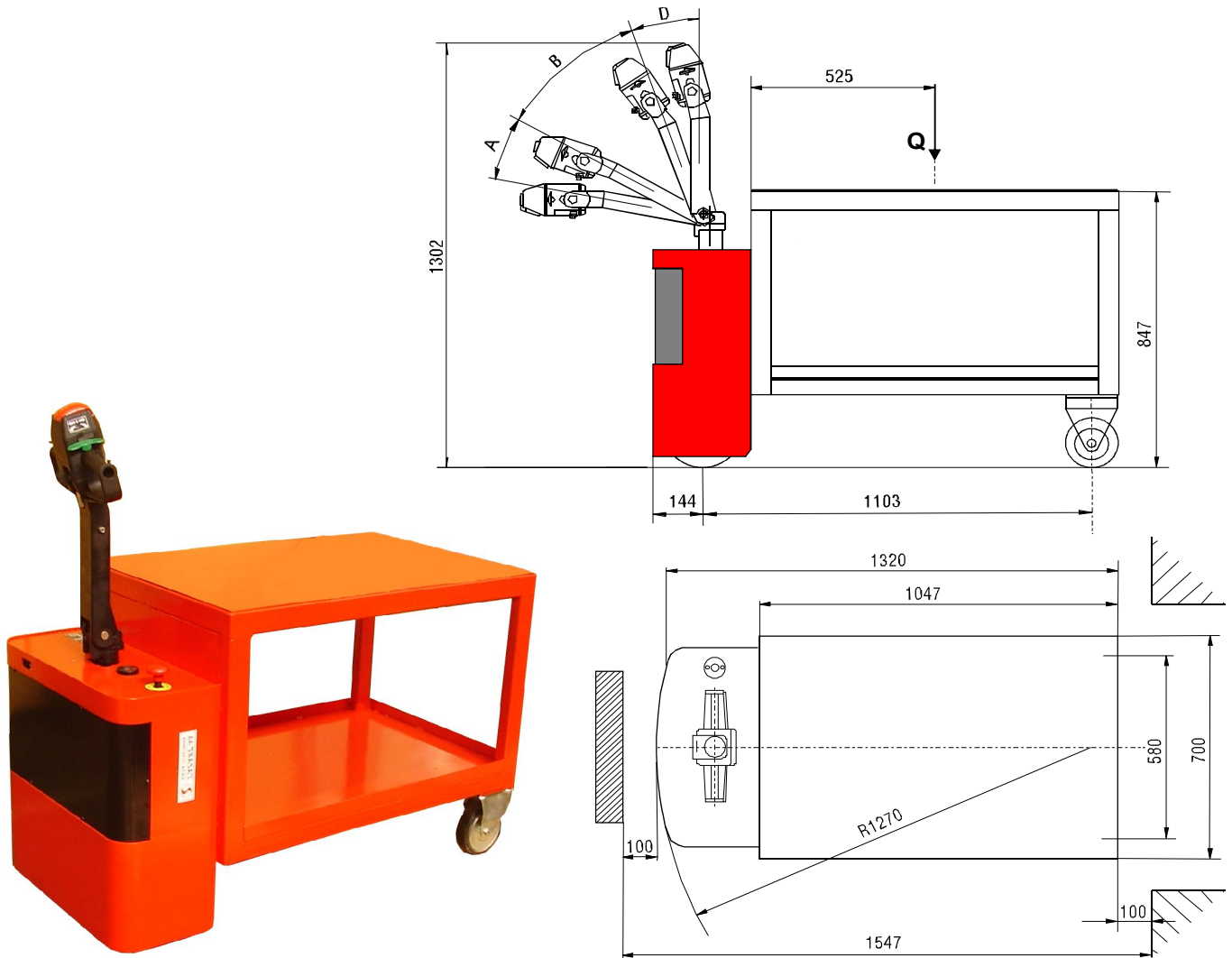

Designation:

Specialized truck which serves for transporting of loads up to 800 kg.

Technical data:

Load Capacity	800	kg
Table dimensions	700x1050	mm
Building height	850	mm
Turning radius	1270	mm
Diameter of motor-wheel	∅ 245	mm
Moving wheel dimensions	∅ 150 x 40	mm
Moving speed with/without load	3 / 3,6	km/h
Climbing ability with/without load	5 / 12	%
Working brake	electric	automatic
Power of electric motor for moving	0,5	kW
Battery	2 x 62 / 12	Ah/V
Weight with a battery	195	kg